

Fullcircle Furniture



This beautiful heirloom furniture has a secret.

It's built from solid birch doors salvaged during the demolition of a building. Sustainably harvested/locally grown birch components, non-toxic finishes, and doors diverted from landfills make this furniture environmentally friendly.

Harvest Table

81"W x 30.5"D x 29"H, Natural or Hazelnut finish
\$1200

Harvest Bench

81"W x 16"D x 18"H, Natural or Hazelnut finish
\$700 each

Harvest Table and Benches

Set **\$2500 (save \$100!)**



www.madisonenvironmental.com

25 N. Pinckney St.

Madison, WI 53703

608-280-0800

christi.weber@madisonenvironmental.com

Fullcircle Furniture

Demolition waste bound for the landfill

Reclaimed materials rescued and reused



A problem to solve

Construction and demolition waste consumes 46% of Dane County landfill space.

Madison Environmental Group began exploring the feasibility of a business solution to divert doors and building materials from our landfills.

During deconstruction of the Meriter Hospital complex, 122 doors were salvaged and furniture was designed to be built from

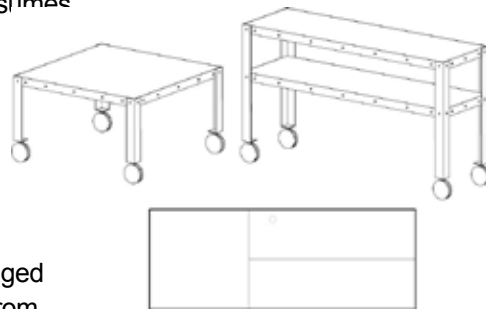

An innovative solution

Breathing new life into many salvaged materials such as commercial doors solves a problem and also satisfies a growing market need for **environmentally friendly products.**

Innovative business models like Fullcircle Furniture and Interiors would provide **new jobs** for Wisconsin while reducing pressure on landfills, using less raw material, and creating greener, healthier interiors.

Partially funded by a grant from the Wisconsin Department of Natural Resources



www.madisonenvironmental.com

25 N. Pinckney St.

Madison, WI 53703

608-280-0800

christi.weber@madisonenvironmental.com

Fullcircle Furniture

These are our Fullcircle prototypes.

The **small table** (*left*) is built using half a door, and the **large table** (*right*) is made from a whole door.

Both tables are constructed using sustainably harvested/locally grown birch and natural linoleum, and are finished with a blend of linseed oil, beeswax and carnuba wax.



Call us to discuss prototype pricing.

The **console** (*left*), **coffee table** (*center*), and **table** (*right*) are built using doors combined with stainless steel. All are finished with a non-toxic product from AFM Safecoat.



www.madisonenvironmental.com
25 N. Pinckney St.
Madison, WI 53703
608-280-0800
christi.weber@madisonenvironmental.com